

RadonAway™

XP/XR Series



Radon Mitigation Fans

Specially designed for radon mitigation, XP/XR Series Fans provide superb performance, run ultra-quiet and are attractive. They are ideal for most subslab radon mitigation systems.

- ◆ 5-Year Warranty
- ◆ Quiet and attractive
- ◆ Thermally protected
- ◆ ETL Listed - for indoor or outdoor use
- ◆ Meets all electrical code requirements
- ◆ Rated for commercial and residential use

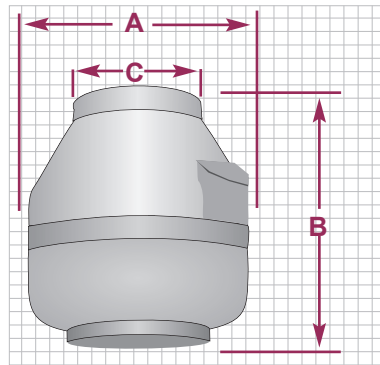
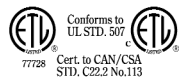

Model	Dimensions		
	A	B	C Duct Size
XP151	8.5"	9.5"	4"
XP201	8.5"	9.5"	4"
XR261	8.5"	9.5"	6"

The following chart shows performance of XP/XR Series fans:

Model	Watts	Maximum Pressure "WC	Typical CFM vs. Static Pressure WC			
			0"	0.5"	1.0"	1.5"
XP151	45-60	1.6	180	140	80	10
XP201	45-66	1.9	125	105	70	35
XR261	65-105	1.8	230	165	75	30

Choice of model is dependent on building characteristics including sub-slab materials and should be made by a radon professional.

FOR FURTHER INFORMATION CONTACT: